

# ferroli

## RHV

AIR COOLED WATER CHILLERS  
WITH HELICAL FANS

332 ÷ 1114 kW



## TECHNICAL MANUAL



# TABLE OF CONTENTS

THIS MANUAL IS DIVIDED INTO SECTIONS. THEIR NAMES APPEAR IN THE HEADING OF EACH PAGE.

<b>GENERAL SPECIFICATIONS</b> .....	<b>4</b>
INTRODUCTION .....	4
IDENTIFICATION CODE OF THE APPLIANCE .....	4
DESCRIPTION OF THE COMPONENTS .....	5
<b>ACCESSORIES AND OPTIONAL EQUIPMENT</b> .....	<b>8</b>
AVAILABLE ACCESSORIES .....	8
MECHANICAL OPTIONS .....	8
ELECTRICAL OPTIONS .....	8
<b>GENERAL SPECIFICATIONS - IR UNIT FOR COOLING MODE ONLY</b> .....	<b>9</b>
GENERAL TECHNICAL SPECIFICATIONS BASIC VERSION UNIT .....	9
ACOUSTIC VERSION: AB (BASIC VERSION) .....	9
STANDARD PERFORMANCES AB - BASIC VERSION .....	10
ACOUSTIC VERSION: AS (LOW NOISE VERSION) .....	11
STANDARD PERFORMANCES AS - LOW NOISE VERSION .....	12
ACOUSTIC VERSION: ASS (EXTRA LOW NOISE VERSION) .....	13
STANDARD PERFORMANCES ASS - EXTRA LOW NOISE VERSION .....	14
BRIVE VERSION (VI) .....	15
<b>TECHNICAL SPECIFICATION RECOVERED HEATING CAPACITY SPECIAL VERSIONS - IR UNITS FOR COOLING ONLY</b> .....	<b>16</b>
VERSION WITH DESUPERHEATER (VD) .....	16
RECOVERED HEATING CAPACITY IN VERSION WITH DESUPERHEATER (VD) .....	17
VERSION WITH TOTAL RECOVERY ON ALL CIRCUITS (VR) .....	18
RECOVERED HEATING CAPACITY IN TOTAL RECOVERY VERSION (VR) .....	18
<b>NOISE LEVELS</b> .....	<b>19</b>
AB BASIC VERSION .....	19
AS LOW NOISE VERSION .....	19
ASS EXTRA LOW NOISE VERSION .....	19
<b>OPERATING RANGE</b> .....	<b>20</b>
OPERATING RANGE BASIC VERSION .....	20
OPERATING RANGE FOR RECOVERED VERSION .....	20
<b>WATER PRESSURE DROP BASIC VERSION</b> .....	<b>21</b>
OPERATING RANGE .....	21
<b>WATER PRESSURE DROP WITH DESUPERHEATER</b> .....	<b>22</b>
OPERATING RANGE .....	22
<b>WATER PRESSURE DROP RECOVERY VERSION</b> .....	<b>23</b>
OPERATING RANGE .....	23
<b>DIMENSIONAL DATA</b> .....	<b>24</b>
DIMENSIONAL DATA AND WEIGHT .....	24
MINIMUM SPACE REQUIRED FOR OPERATION .....	24
VICTAULIC CONNECTIONS .....	24

## GENERAL SPECIFICATIONS

### Presentation of the Unit

This new series of air-cooled water chillers with helical fans is suitable for outdoor installation: the bearing structure and panelling are made of adequately thick, coated and galvanized sheet metal. All the fastening components are made of stainless and/or galvanized steel. The cabinet that houses the electrical components and all the parts exposed to outdoor weather conditions (fans, pressure switches, valves, etc.) have a protection degree of at least **IP54**.

When the units were designed, particular attention was also paid to sound emission in our endeavour to comply with the increasingly more restrictive laws governing acoustic pollution. The units are therefore available in the basic, silenced and mute versions.

The units produce cold water from 6 to 12°C through to the maximum air temperature of 45/46°C. If equipped with the accessory head pressure control the units can operate at low outdoor temperatures down to about -10°C.

They are equipped with 2 independent refrigerant circuits, each of which has a semi-hermetic **TWIN-SCREW** compressor featuring a 25 to 100% control capacity device.

As part of the standard outfit, the units are also equipped with a shell and tube heat exchanger evaporator optimized for use with **R134a**, featuring high-efficiency grooved pipes and thermally insulated and protected by means of a differential water pressure switch and electrical antifreeze heater that enables the exchanger to be protected against winter freezing down to a min. air temperature = -10°C, coils with extended surfaces and extensive heat exchanging areas formed by copper pipes and louvered aluminium fins, electric fans with scythe-shaped blades to reduce the sound emission, electric panel for setting and controls with a door-locking main circuit-breaker, controller with microprocessor plus display with 4 lines of 20 characters, **R134a** environment-friendly refrigerant gas.

The evaporator is fed by an electronic expansion valve that allows the exploitation of the evaporator surface thus increasing the efficiency of the system in all working conditions (25 to 100%) so achieving the optimal seasonal energy efficiency,

All the units are accurately built and tested individually, thus only the electrical and wet connections need be made for installation.



### Identification code of the unit

The codes that identify the units are listed below and include the sequences of letters that determine the meanings for the various versions and set-ups.

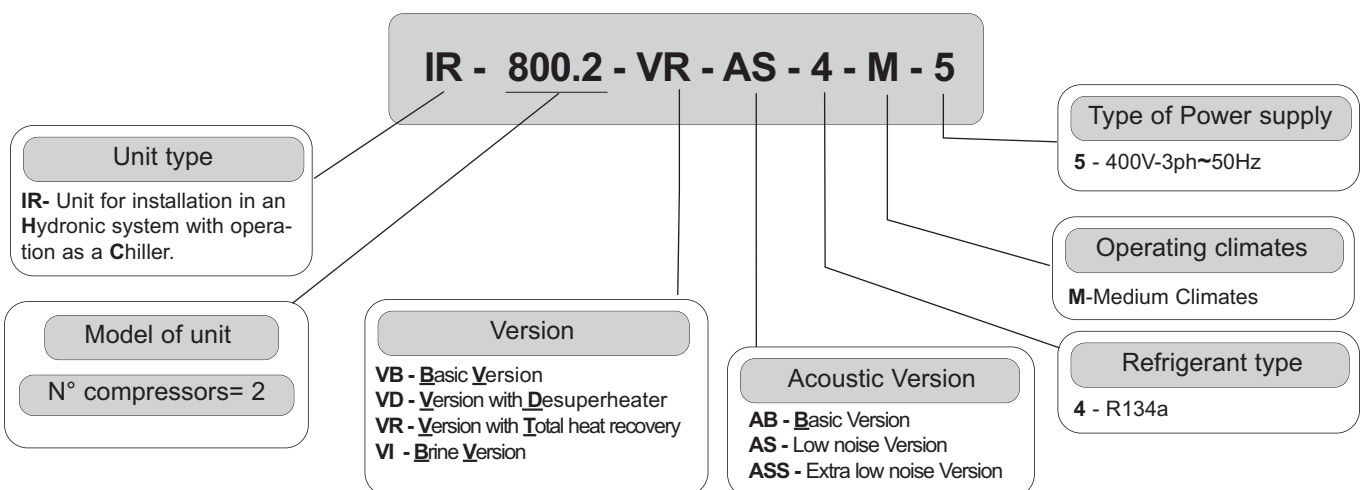

## GENERAL SPECIFICATIONS

### Acoustic versions

The available unit versions are described below:

**AB: Basic Version.** The compressors in these units are installed without a soundproofed cabinet and with axial fans operating at 900 rpm.

**AS: Low Noise Version.** The units are as standard equipped with head pressure control, made with compressors installed inside a soundproofed cabinet, helical fans working at low speed rotation at nominal condition. The unit can work with low noise emission up to an external air temperature of 40°C. Compared with the Basic Version the noise level is reduced of 5/6 dB.

**ASS: Extra Low Noise Version.** The units are as standard equipped with head pressure control, made with compressors installed inside a soundproofed cabinet, helical fans working at very low speed rotation at nominal condition and coils with increased surface. The unit can work with low noise emission up to an external air temperature of 38°C. Compared with the Basic Version the noise level is reduced of 10/11 dB.

### Special versions

The available special versions are described below:

**VB: Basic version.** The unit can produce cold water at a temperature of **6 to 12°C**.

**VD: Version with Desuperheater.** Produces cold water as in the standard version plus hot water at a temperature from 40 to 50°C at the same time. This is achieved thanks to a water-refrigerant gas heat exchanger between the compressors and condensing coils that recovers part of the thermal power that would otherwise be dispersed in the air.

**VR: Version with Total/Partial heat Recovery.** Produces cold water as in the standard version plus hot water at a temperature from 35 to 50°C at the same time. This is achieved thanks to a water-refrigerant gas heat exchanger that totally recovers the thermal power that would otherwise be dispersed in the air. The total heat recovery function is enabled and disabled by means of a valve on the compressor discharge of each circuit: when the temperature of the water that enters the recuperator drops, the valve switches the hot gas flow from the condensing coils to the recovery heat exchanger. On the other hand, when the temperature of the water reaches the set-point, the valve shuts off the heat recuperator and switches the hot gas flow to the condensing coils.

**VI: Version that produces water at a low temperature (BRINE)**

The unit can produce cold water with brine at a temperature of **-8 to 4°C**.

### Description of the components

**1. Fans.** These are the helical type with scythe-shaped blades to increase efficiency and reduce the sound emissions. The fans are directly coupled to the threephase motor by means of an external rotor. Thermal protection against operating faults is installed inside the winding.

### 2. Electric control and monitoring panel.

It is housed in a cabinet made of adequately thick painted sheet metal suitable for outdoor installation (protection degree IP 54). The panel comprises the following main components:

- Main door-locking circuit-breaker.
- Contactors to control and manage the part-winding or star-delta starting mechanism of each compressor.
- Fuse holders with protection fuses for each compressor.
- Fuse holders with protection fuses for the oil heaters of the compressors.
- Fuse holders with protection fuses for the antifreeze heater.
- Fuse holders and protection fuses for the fans.
- Fan control contactors.
- Insulating and safety transformer to power the auxiliaries, protected with fuses.
- Basic monitoring board with microprocessor:
- Electronic expansion valve controller

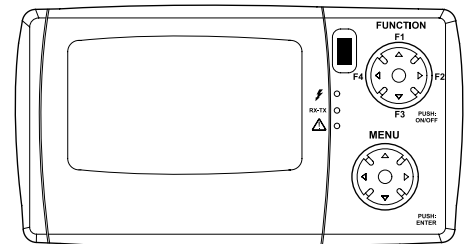

### The main functions of the monitoring system are:

Temperature regulation of the water produced by the unit, operating hour counting for compressors and pump/s, operating hour balancing for compressors and pumps, start-up timing, parameter entry digitized via the keyboard, alarm diagnosis.

**Functions associated with the digital inputs:** high and low pressure, high discharge temperature, correct electric power phase presence-sequence, thermal protection for compressors, thermal protection for fans, thermal protection for pump, differential water pressure switch, remote controlled ON/OFF commands.

**Functions associated with the digital outputs:** compressor control, solenoid valve for compressor control capacity, liquid solenoid valve control, water pump/s control, electric antifreeze heater, ventilating step control for condensation control function, general alarm (can be remote controlled).

**Functions associated with the analog inputs:** water inlet and outlet temperatures, coil temperature.

Suction and discharge pressure, oil pressure, delivery temperature probe. Suction temperature, liquid temperature, liquid probe.

**Functions associated with the analog outputs:** speed control (only with DCC Head pressure control accessory).

### 3. User interfacing terminal with display.

The interface consists of:

- FUNCTION/ON-OFF multifunction key for quick access to the 4 main menus and for powering/switching off.
- MENU multifunction key to access all the menus for controlling and configuring the unit.
- **Power-on LED.**
- **RX-TX LED** to indicate that the user interface and monitoring module are communicating.
- **Alarm indicator LED.**
- Check-control with alarm display.

## GENERAL SPECIFICATIONS

**4. Bearing structure** made of galvanized sheet metal coated with polyurethane powder paint to ensure good protection against adverse weather conditions.

**5. Condensing coils**, the aluminium finned pack type with shaped profile to increase the heat exchange coefficient and with copper pipes arranged in staggered rows. A sub-cooling section is integrated into the lower part.

**6. Covering panels**, made of galvanized sheet metal coated with polyurethane powder paints to ensure the utmost ability to withstand adverse weather conditions.

**7. Compressor cabinet (only for AS and ASS)**. They are installed in a soundproofed booth made of galvanized sheet metal coated with polyurethane powder paints and covered in soundproofing material.

**8. Compressors**. Suitable for outdoor installation. They are the **TWIN-SCREW type with 25 to 100% control capacity**: in conjunction with accurate assembly, this technical solution allows the refrigerant to compress and the axial thrusts on the bearings (amongst the most critical components of the compressor) to be perfectly balanced, thus guaranteeing long life.

They are equipped with an asynchronous three-phase motor (400V-3-50Hz) with aluminium squirrel-cage rotor, pre-engineered for part-winding or star-delta starting (so as to reduce the current input during the starting phase to the minimum) and are protected by a chain of thermostats buried in the stator windings (controlled by an electronic module) and fuses housed in the electric panel.

The standard outfit includes an efficient oil separator complete with electric heater (activated when the compressor stops). To widen the field of application to an even greater extent, some models are equipped with a liquid injection system controlled by the electronic controller so that use only occurs when effectively necessary.

As part of the standard supply, they are positioned on rubber vibration dampers to reduce the vibrations transmitted to the base of the unit.

**9. Evaporator** of the shell and tube heat exchanger type, made of carbon steel and optimized for operation with **R134a**. Features high-efficiency grooved pipes and also achieves low losses on the wet side.

As standard, the evaporator is insulated with 19mm flexible closed-cell foam that forms barrier to prevent the formation of condensation and heat exchanges towards the outside. Standard supply also includes a differential water pressure switch built into the water supply circuit to avoid the risk of freezing if the water flow is shut off for some reason and electrical antifreeze heater that enables the exchanger to be protected against winter freezing down to a min. air temperature = -10°C. Also ensures that mechanical stress is absorbed to a good degree. As accessory it can be supplied with Water flow switch FA.

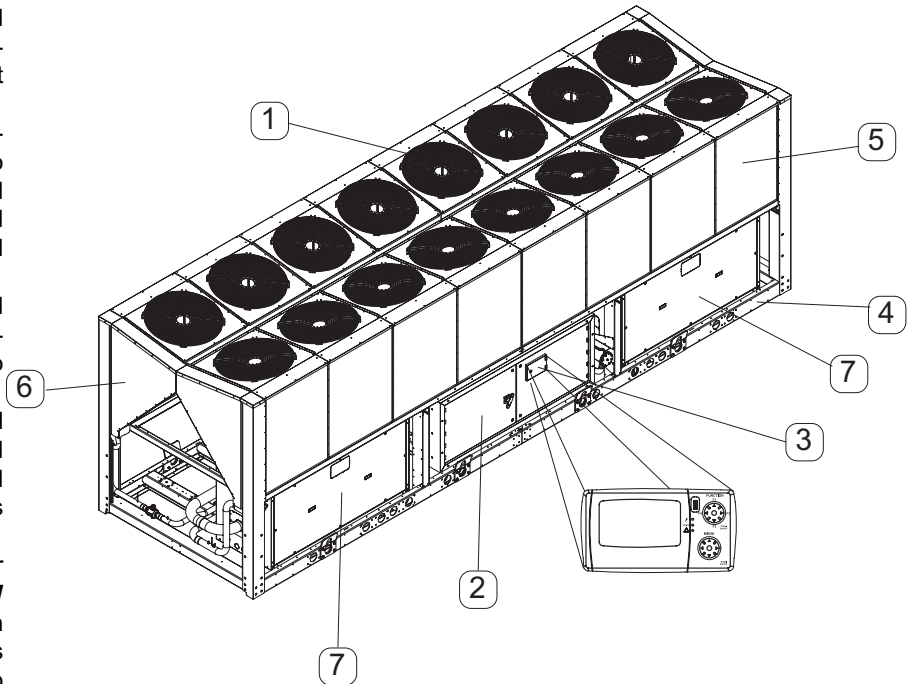

### Hydraulic and refrigerant circuit components

**10. Refrigerant safety valve**. (Conforms to the Directive governing pressurized equipments - PED) Installed on the delivery pipe of the compressors. It acts if critical service faults should occur.

**11A. Liquid cock - 11B. Gas cock**. Allow all the refrigerant in the coils to be pumped and then stored so as to carry out servicing work or to replace all the components of the chilling circuit without having to drain it.

**12. Dehydrator filter**. Of the removable cartridge type. Retains impurities and traces of moisture in the circuit.

**13. Liquid injection solenoid valve**, to allow a larger operating envelope directly managed by electronic controller.

**14. Electronic expansion valve**. It has the task of correctly feeding the evaporator insuring a steady superheat. The valve is managed by a dedicated electronic board. It has also the function to stop the liquid when the compressor is off, so avoiding the refrigerant migration from the coils to the evaporator and to the compressor.

- **Liquid injection solenoid valve**. One per circuit. They shut off when the compressor switches off, preventing liquid refrigerant from flowing towards the evaporator during standstill periods.

**15. Compressor delivery probe**. One per compressor, installed on the delivery pipe to protect the compressor if the end of compression temperature exceeds the established limits.

- **Economizer**. The refrigerant circuit for some models is integrated with an economizer. This device increases the cooling capacity and efficiency (EER) of the unit at all operating conditions of the compressor (from 25% to 100%).

## GENERAL SPECIFICATIONS

**Liquid and moisture sight glass.** Signals when liquid passes through the circuit, indicating that the refrigerant charge is correct. The liquid indicator also changes colour to show the amount of moisture in the refrigerant.

- **Pressure taps:** 1/4 " SAE (7/16" UNF) (schraeder). Allow the operating pressure of both the circuits to be measured in 3 main points of each refrigerant circuit: compressor discharge, thermostatic valve inlet, compressor suction.

- **High pressure switch.** With fixed setting. It is installed on the delivery pipe and blocks the compressor of the circuit if the operating pressures exceed the tolerated values. If it activates, the circuit will block and can only be restarted by resetting via the user interface terminal.

- **Oil crankcase heater** to heat the compressor oil. One per compressor. Activated when the compressor switches off. Their task is to keep the temperature of the oil sufficiently high so as to prevent refrigerant from migrating during these pauses.

- **Low pressure switch.** With fixed setting. It is installed on the suction pipe and blocks the compressors if the operating pressures drop below the tolerated values. Automatically resets as the pressure increases. If it activates frequently, the unit will block and can only be restarted by resetting via the user interface terminal.

### Recovery Version components VD / VR

**16. Heat recovery exchanger.** Specially designed for the specific version. Plate type or shell and tube, it is insulated with 19mm flexible closed-cell foam that forms barrier to prevent heat exchanges towards the outside. On request for some models it can be equipped with an electric antifreeze heater to prevent the components from freezing during winter periods at a standstill if the unit is not drained.

### Only Recovery Version VR

**17. Heat recovery management valve.** This delivers refrigerant to the condensing coils or heat recovery exchanger, depending on demands for hot water.

**18. Liquid receiver.** This is a plenum tank that accounts for the refrigerant charge variations required by the machine as the operating modes change (condensing in air or in water).

- **Differential water pressure switch** that disables the heat recovery function if water fails to flow to the exchangers.

- **Liquid solenoid valves.** Allow the refrigerant charge to be recovered after operating mode changes from recovery to cooling and vice versa.

- **One-way valves.** Make the refrigerant obligatorily pass through the appropriate heat exchangers (coils / heat recuperator), depending on the operating mode.

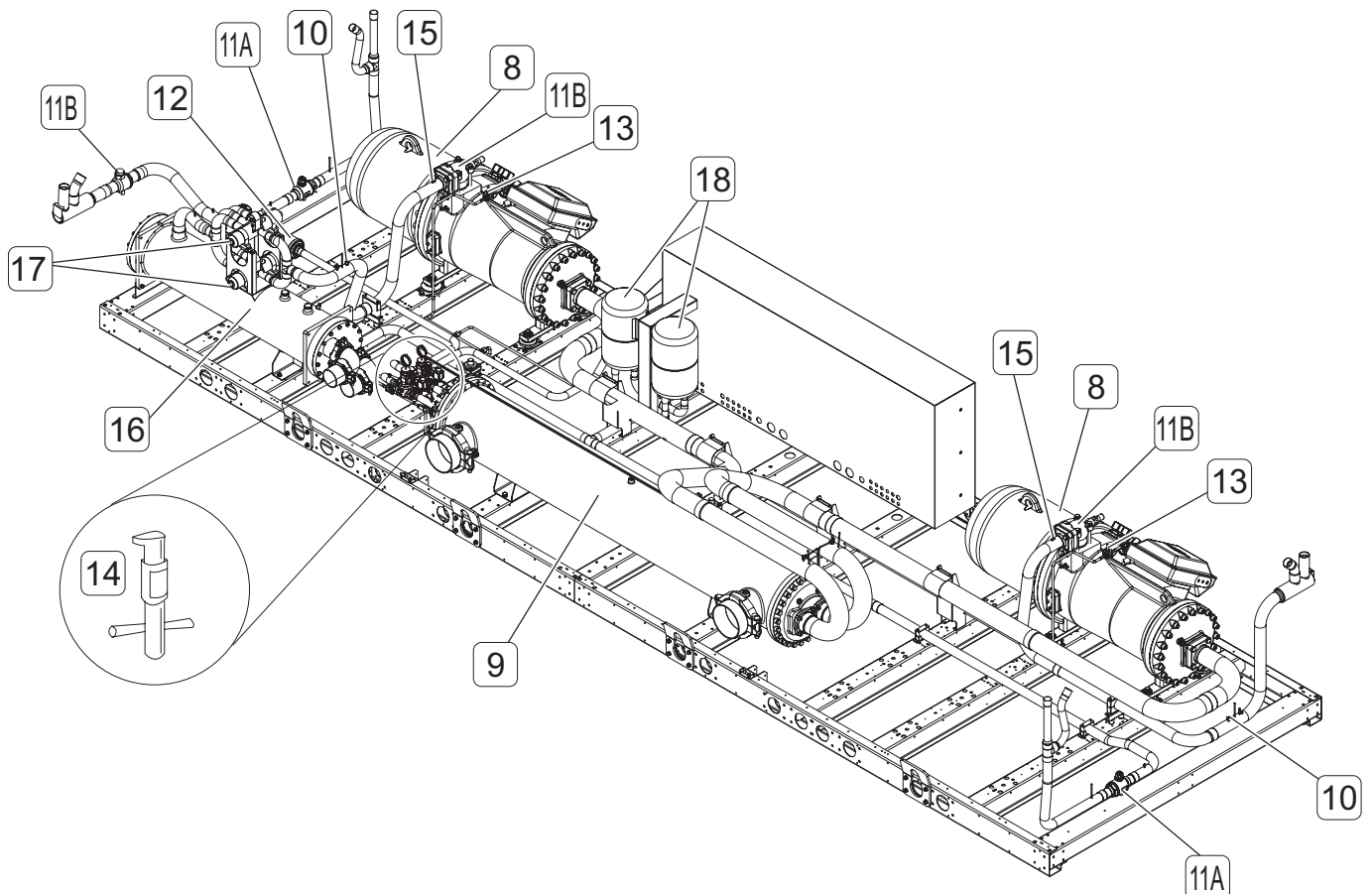

## ACCESSORIES AND OPTIONAL EQUIPMENT

---

### Available accessories

---

**NOTE: The accessories can be of the following type:**

**(M):** only installed in the factory.

**(F):** supplied for installation by the customer.

**MP (F) Storage and Pumping Module (Storage on the Delivery or Storage on Return).** The purpose of the storage and pumping module is to lower the number of compressor surges, increasing the amount of water in the system and, thus, its thermal inertia. It consists of a base made of galvanized and painted sheet metal and aluminium sheet panelling suitable for outdoor installation.

Designed for connection alongside the chiller, the accessory comprises an insulated carbon steel tank, a **single or double centrifugal pump** with on-off valves, an electric power panel, expansion tank, safety valve, air vent, pressure gauge and filling and draining valves.

**FLS (M) Water paddle flow switch.**

**RAG 8 (M) Antifreeze heating element for Pumping Module Water tank.**

**GM (M) Pressure gauge unit.** This consists of low pressure gauges and high pressure gauges (one low and one high pressure gauge for circuit).

**GP (M) Protective guard for the coils.** Consisting of metal guard that protect the coils.

**GP (M) Anti-intrusion guard.** Consisting of metal guard that protect the acces to hydraulic and refrigerant circuit.

**RB(M) Compressor suction shut-off valve.**

**AVM (F) Spring vibration dampers.** Consisting of an adequate number of spring vibration dampers, which varies depending on the model, to install under the unit. They reduce the mechanical vibrations generated by the compressor and fans during their normal operation, that are then transmitted to the bearing surface of the machine. The insulation degree provided by the vibration dampers is about 90%.

**OP (F) Programmer Clock,** applied to the remote ON/OFF function.

**CR (F) Remote Control.** Repeats the functions of the control system installed in the unit, thus allowing this latter to be controlled at a distance (up to 100 m) from the unit.

**INT (M) RS485 Serial interface,** for communication with the MODBUS protocol.

**CSF (M) Voltage monitor and sequence meter.** The device enables control of the correct sequence of power phases and the lack of any phases. It also ensures that the unit works within  $\pm 10\%$  the rated voltage (MIN=360 V - RATED=400V - MAX=440V). It blocks the unit if the voltage is outside the limits provided for.

**DCC (M) Head pressure control** (as standard per low noise version AS and per Extra low noise version ASS).

The device is made by 2 electrical drivers that, by means of phase cutting, control the fans speed rotation, with the scope of maintaining the condensation pressure inside the correct operating limits.

---

### Mechanical options

---

**Special finned heat exchangers**

- Coils with copper fins
- Coils with aluminium fins with black cataphoresis treatment

---

### Electrical options

---

**For power supply voltage different from 400V-3ph~50Hz contact our Sales Office.**

## GENERAL SPECIFICATIONS - IR UNIT FOR COOLING MODE ONLY

### General technical specifications Basic Version Unit

### Acoustic Version: AB (Basic Version)

The following data refer to an IR unit using R134a refrigerant

Model	330.2	370.2	420.2	470.2	510.2	590.2	670.2	740.2	800.2	900.2	1000.2	1150.2	UM
Cooling capacity <sup>(1)</sup>	332	366	415	468	511	594	665	743	802	892	987	1114	kW
Total power input <sup>(1)</sup>	119	136	151	165	188	210	225	260	281	323	352	379	kW
EER <sup>(1)</sup>	2,78	2,69	2,75	2,83	2,72	2,83	2,96	2,86	2,86	2,76	2,80	2,94	W/W
ESEER	3,63	3,51	3,62	3,74	3,60	3,76	3,85	3,82	3,81	3,72	3,78	4,01	W/W
Refrigerant charge	Take as reference the refrigerant charge value on the Unit Identification plate												kg

### Compressor specifications

Type	TWIN-SCREW												-
Quantity	2												N°
Capacity control	25-100 %												%
Starting type	PART WINDING						STAR-DELTA						-
Power input	104	121	136	150	169	191	206	237	258	296	326	349	kW

### Exchanger data

Type	SHELL AND TUBE HEAT EXCHANGER												-
Quantity	1												N°
Maximum pressure on wet side	1000												kPa
Total water capacity	113	108	159	159	154	263	256	241	241	419	410	401	l
Water flow rate <sup>(1)</sup>	15,9	17,5	19,8	22,4	24,4	28,4	31,8	35,5	38,3	42,6	47,2	53,2	l/s
Water pressure drop <sup>(1)</sup>	49	57	44	56	53	53	44	45	52	60	42	56	kPa

### Fan specifications

Quantity	8	8	8	8	10	10	10	12	12	14	14	16	N°
Diameter [ Ø ]	800												mm
Maximum rotation speed	900												rpm
Maximum motor input power	2												kW
Total air flow rate	45900	45900	45000	44100	57120	54880	51520	64000	61870	76930	72220	82570	l/s
Total power input	14,4	14,4	14,4	14,4	18,0	18,0	18,0	21,6	21,6	25,2	25,2	28,8	kW

### Electrical specifications

Electric power supply	400 / 3 / 50												V/ph/Hz
FLA Maximum current input	274	304	332	360	409	469	469	557	594	684	746	755	A
FLI Maximum power input	164	184	200	216	242	282	282	339	364	412	452	456	kW
MIC Maximum surge current	504	592	689	717	838	921	921	751	788	958	1053	1062	A

#### NOTES:

(1): The data refer to: Water temperature: inlet: 12°C - outlet: 7°C, Outdoor air temperature 35°C D.B.

### Specifications of coils with extended surfaces

Type	Copper pipes notched aluminium fins												/	
Quantity	4												N°	
Total area	18			22.4			26.9			31.4			35.9	m²

### Noise levels

Total SWL	98	98	98	98	100	100	100	101	101	102	102	103	dB(A)
SPL 1 m	79	79	79	79	80	80	80	80	80	81	81	82	dB(A)
SPL 5 m	71	71	71	71	72	72	72	73	73	74	74	75	dB(A)
SPL 10 m	66	66	66	66	67	67	67	69	69	69	69	70	dB(A)

The noise levels refer to units operating in the nominal conditions (water temperature: inlet: 12°C - outlet: 7°C, Outdoor air temperature 35°C). The acoustic pressure levels are measured 1/ 5 / 10 meters away from the outer surface of the unit operating in the free field and resting on a reflecting surface (directional factor of 2).

**SWL** = Sound power levels, with reference to  $2 \times 10^{-12}$  W.

The **Total** sound power level in **dB(A)** measured in compliance with **ISO 9614** standards, is certified according to the **Eurovent** certification program.

Eurovent certification (**E**) exclusively refers to the **Total** Sound Power in **db(A)**, which is therefore the only binding acoustic specification (the values of the Octave bands in the table are indicative).

**SPL** = Sound pressure levels, with reference to  $2 \times 10^{-5}$  Pa.

The sound pressure levels are values calculated by applying the **ISO-3744 relation (Eurovent 8/1)** and refer to a distance of 1 meter away from the external surface of units operating in the open field with directivity factor 2 and the units operating in nominal conditions in the cooling mode.

## GENERAL SPECIFICATIONS - IR UNIT FOR COOLING MODE ONLY

### Standard performances - Basic Version VB

MODEL	TW	OUTDOOR AIR TEMPERATURE (°C D.B.)											
		25		30		35		40		43		45	
		kWf	kWa	kWf	kWa	kWf	kWa	kWf	kWa	kWf	kWa	kWf	kWa
330	6	363	87	341	95	320	103	300	111	287	115	280	119
	7	375	89	353	96	<b>332</b>	<b>104</b>	311	112	298	117	291	120
	8	388	90	365	98	344	105	322	113	309	118	302	121
	9	400	92	377	99	355	107	333	114	320	119	-	-
	10	413	93	389	100	367	108	344	115	331	120	-	-
11	428	95	403	102	379	109	356	117	342	121	-	-	
370	6	397	102	375	110	354	120	333	129	320	134	313	139
	7	411	103	388	112	<b>366</b>	<b>121</b>	344	130	331	136	324	140
	8	424	105	400	113	378	122	356	132	343	137	335	141
	9	437	107	413	115	391	124	368	133	354	138	-	-
	10	450	109	426	117	403	125	380	134	366	139	-	-
11	467	110	441	118	416	127	392	136	377	141	-	-	
420	6	450	113	425	123	401	134	378	145	364	152	356	157
	7	464	115	439	125	<b>415</b>	<b>136</b>	391	147	377	153	368	159
	8	479	117	453	127	429	138	404	148	389	155	381	160
	9	494	119	468	129	443	139	417	150	402	156	-	-
	10	509	120	482	130	456	141	431	151	415	158	-	-
11	527	122	499	132	471	142	444	153	428	159	-	-	
470	6	506	124	479	136	453	148	427	161	411	169	402	175
	7	523	126	495	137	<b>468</b>	<b>150</b>	441	163	426	170	416	176
	8	539	127	510	139	483	152	456	164	440	172	431	178
	9	556	129	526	141	499	153	471	166	454	174	-	-
	10	572	131	542	142	514	155	486	168	469	175	-	-
11	592	132	561	144	531	157	501	169	483	177	-	-	
510	6	556	143	524	154	494	167	463	179	445	186	434	118
	7	575	145	542	157	<b>511</b>	<b>169</b>	480	181	461	189	451	120
	8	594	148	560	159	528	171	497	184	478	191	467	121
	9	613	151	578	162	546	174	514	186	494	193	-	-
	10	631	153	596	164	563	176	531	189	511	196	-	-
11	654	156	618	167	583	179	548	191	527	198	-	-	
590	6	643	159	608	173	574	189	541	204	521	214	510	221
	7	664	161	628	175	<b>594</b>	<b>191</b>	560	207	539	216	528	223
	8	686	164	649	178	614	193	579	209	558	218	546	225
	9	707	166	669	181	633	196	597	211	576	220	-	-
	10	729	169	690	183	653	198	616	213	594	223	-	-
11	755	171	714	186	675	201	636	216	612	225	-	-	
670	6	720	171	680	187	643	203	606	220	583	230	571	238
	7	744	174	703	189	<b>665</b>	<b>206</b>	627	223	604	233	591	241
	8	768	177	726	192	687	209	648	225	624	235	611	243
	9	792	180	749	195	709	211	669	228	645	238	-	-
	10	816	182	772	197	731	214	690	230	665	240	-	-
11	845	185	799	200	755	217	712	233	686	243	-	-	
740	6	803	196	760	214	719	234	678	254	653	266	639	276
	7	829	199	785	217	<b>743</b>	<b>237</b>	701	257	676	269	661	278
	8	856	202	810	220	767	240	724	259	699	271	684	281
	9	882	205	836	223	792	243	748	262	721	274	-	-
	10	908	208	861	226	816	245	771	265	744	277	-	-
11	940	210	890	228	843	248	796	268	767	280	-	-	
800	6	867	214	820	233	776	255	731	277	705	290	690	300
	7	895	217	847	236	<b>802</b>	<b>258</b>	757	280	729	292	714	303
	8	924	220	875	240	828	261	782	282	754	295	738	306
	9	952	223	902	243	855	264	807	285	779	298	-	-
	10	980	226	929	246	881	267	832	288	803	301	-	-
11	1.015	229	961	249	910	270	859	292	828	304	-	-	
900	6	972	250	915	270	862	292	808	313	776	326	758	337
	7	1.004	254	947	274	<b>892</b>	<b>296</b>	837	318	805	331	786	341
	8	1.037	259	978	279	922	300	867	322	833	335	815	345
	9	1.069	264	1.009	284	953	305	896	326	862	339	-	-
	10	1.102	269	1.041	288	983	309	925	330	891	343	-	-
11	1.142	273	1.078	293	1.017	314	956	335	919	348	-	-	
1000	6	1.069	274	1.010	297	955	322	900	346	866	361	847	373
	7	1.104	278	1.044	301	<b>987</b>	<b>326</b>	930	351	896	366	877	377
	8	1.139	283	1.077	306	1.019	330	961	355	926	370	906	381
	9	1.174	288	1.111	311	1.051	335	991	359	956	374	-	-
	10	1.209	293	1.144	315	1.083	339	1.022	364	985	378	-	-
11	1.251	297	1.183	320	1.118	344	1.054	368	1.015	383	-	-	
1150	6	1.207	293	1.140	318	1.078	344	1.015	371	978	387	956	400
	7	1.246	298	1.178	323	<b>1.114</b>	<b>349</b>	1.050	375	1.011	391	989	404
	8	1.285	303	1.216	328	1.150	354	1.084	380	1.045	396	1.022	408
	9	1.325	308	1.254	333	1.186	359	1.119	385	1.079	400	-	-
	10	1.364	314	1.291	338	1.222	363	1.153	389	1.112	405	-	-
11	1.413	318	1.335	342	1.262	368	1.189	394	1.146	410	-	-	

TW= Outlet water temperature °C

kWf = Cooling capacity (kW).

kWa = Compressor power input (kW)

The standard performances refer to a 5°C temperature difference between the water entering and leaving the heat exchanger and to operation of the unit with all fans at top speed. A  $0.44 \times 10^{-4} \text{ m}^2 \text{ K/W}$  fouling factor has also been considered with the unit installed at zero meters above sea level (Pb = 1013mbar).

## GENERAL SPECIFICATIONS - IR UNIT FOR COOLING MODE ONLY

### Acoustic Version: AS (Low noise version)

The following data refer to an IR unit using R134a refrigerant

Model	330.2	370.2	420.2	470.2	510.2	590.2	670.2	740.2	800.2	900.2	1000.2	1150.2	UM
Cooling capacity <sup>(1)</sup>	321	354	399	447	494	567	642	715	769	856	943	1080	kW
Total power input <sup>(1)</sup>	118	136	151	167	187	215	235	265	290	327	361	391	kW
EER <sup>(1)</sup>	2,72	2,61	2,63	2,68	2,64	2,64	2,73	2,70	2,65	2,62	2,61	2,76	W/W
ESEER	3,75	3,58	3,61	3,67	3,61	3,60	3,74	3,68	3,64	3,61	3,60	3,86	W/W
Refrigerant charge	Take as reference the refrigerant charge value on the Unit Identification plate												kg

### Compressor specifications

Type	TWIN-SCREW												-
Quantity	2												N°
Capacity control	25-100 %												%
Starting type	PART WINDING						STAR-DELTA						-
Power input	108	126	142	157	175	203	223	251	276	310	345	372	kW

### Exchanger data

Type	SHELL AND TUBE HEAT EXCHANGER												-
Quantity	1												N°
Maximum pressure on wet side	1000												kPa
Total water capacity	113	108	159	159	154	263	256	241	241	419	410	401	l
Water flow rate <sup>(1)</sup>	15,3	16,9	19,1	21,4	23,6	27,1	30,7	34,2	36,7	40,9	45,1	51,6	l/s
Water pressure drop <sup>(1)</sup>	46	54	40	51	50	48	41	41	47	55	39	53	ka

### Fan specifications

Quantity	8	8	8	8	10	10	10	12	12	14	14	16	N°	
Diameter [ Ø ]	800													
Nominal/Maximum rotation speed	700/900												rpm	
Maximum motor input power	2												kW	
Total air flow rate	nom	35280	34020	33100	32040	43904	42336	39872	48950	47882	59346	55892	63902	l/s
	max	45900	45900	45000	44100	57120	54880	51520	64000	61870	76930	72220	82570	l/s
Total power input	nom	8,0	8,0	8,0	8,0	10,0	10,0	10,0	12,0	12,0	14,0	14,0	16,0	kW
	max	14,4	14,4	14,4	14,4	18,0	18,0	18,0	21,6	21,6	25,2	25,2	28,8	kW

### Electrical specifications

Electric power supply	400 / 3 / 50												V/ph/Hz
FLA Maximum current input	274	304	332	360	409	469	469	557	594	684	746	755	A
FLI Maximum power input	164	184	200	216	242	282	282	339	364	412	452	456	kW
MIC Maximum surge current	504	592	689	717	838	921	921	751	788	958	1053	1062	A

#### NOTES:

(1): The data refer to: Water temperature: inlet: 12°C - outlet: 7°C, Outdoor air temperature 35°C D.B.

### Specifications of coils with extended surfaces

Type	Copper pipes notched aluminium fins												/	
Quantity	4												N°	
Total area	18			22.4			26.9			31.4			35.9	m²

### Noise levels

Total SWL	93	93	93	93	94	94	94	96	96	97	97	98	dB(A)
SPL 1 m	73	73	73	73	74	74	74	75	75	75	75	76	dB(A)
SPL 5 m	65	65	65	65	67	67	67	68	68	69	69	69	dB(A)
SPL 10 m	61	61	61	61	62	62	62	63	63	64	64	65	dB(A)

The noise levels refer to units operating in the nominal conditions (water temperature: inlet: 12°C - outlet: 7°C, Outdoor air temperature 35°C). The acoustic pressure levels are measured 1/ 5 / 10 meters away from the outer surface of the unit operating in the free field and resting on a reflecting surface (directional factor of 2).

**SWL** = Sound power levels, with reference to  $2 \times 10^{-12}$  W.

The **Total** sound power level in **dB(A)** measured in compliance with **ISO 9614** standards, is certified according to the **Eurovent** certification program.

Eurovent certification (**E**) exclusively refers to the **Total** Sound Power in **db(A)**, which is therefore the only binding acoustic specification (the values of the Octave bands in the table are indicative).

**SPL** = Sound pressure levels, with reference to  $2 \times 10^{-5}$  Pa.

The sound pressure levels are values calculated by applying the **ISO-3744 relation (Eurovent 8/1)** and refer to a distance of 1 meter away from the external surface of units operating in the open field with directivity factor 2 and the units operating in nominal conditions in the cooling mode.

# GENERAL SPECIFICATIONS - IR UNIT FOR COOLING MODE ONLY

## Standard performances - Low noise version AS

MODEL	TW	OUTDOOR AIR TEMPERATURE (°C D.B.)											
		25		30		35		40		43		45	
		kWf	kWa	kWf	kWa	kWf	kWa	kWf	kWa	kWf	kWa	kWf	kWa
330	6	351	91	330	98	310	107	290	115	278	120	271	124
	7	363	92	341	100	<b>321</b>	<b>108</b>	301	116	288	121	282	125
	8	375	94	353	101	332	109	311	117	299	122	292	126
	9	387	95	364	103	343	111	322	119	309	123	-	-
	10	399	97	376	104	354	112	333	120	320	124	-	-
11	414	98	390	106	367	113	344	121	330	126	-	-	
370	6	384	106	363	115	342	124	322	134	309	140	302	145
	7	397	108	375	116	<b>354</b>	<b>126</b>	333	136	320	141	313	146
	8	410	109	387	118	366	128	344	137	332	143	324	147
	9	423	111	400	120	378	129	356	138	343	144	-	-
	10	436	113	412	122	390	131	367	140	354	145	-	-
11	452	115	426	123	403	132	379	141	365	147	-	-	
420	6	432	118	408	129	386	140	363	152	350	159	342	164
	7	447	120	422	131	<b>399</b>	<b>142</b>	376	153	362	160	354	166
	8	461	122	436	132	412	144	389	155	374	162	366	167
	9	475	124	450	134	425	145	401	157	387	163	-	-
	10	489	126	463	136	439	147	414	158	399	165	-	-
11	507	127	479	138	453	149	427	160	412	166	-	-	
470	6	483	130	457	142	432	155	408	169	393	177	384	183
	7	499	132	472	144	<b>447</b>	<b>157</b>	422	170	406	178	398	185
	8	515	133	488	146	462	159	436	172	420	180	411	186
	9	531	135	503	147	476	161	450	174	434	182	-	-
	10	547	137	518	149	491	162	464	175	448	183	-	-
11	566	139	536	151	507	164	478	177	461	185	-	-	
510	6	538	148	507	160	477	172	448	185	430	193	420	118
	7	556	150	524	162	<b>494</b>	<b>175</b>	464	188	446	195	436	120
	8	574	153	542	165	511	178	480	190	462	198	451	121
	9	592	156	559	168	528	180	497	193	478	200	-	-
	10	610	159	577	170	545	183	513	195	494	203	-	-
11	633	161	597	173	563	185	530	198	510	205	-	-	
590	6	614	169	580	184	548	200	516	217	497	227	487	235
	7	634	171	600	187	<b>567</b>	<b>203</b>	534	219	515	229	504	237
	8	655	174	619	189	586	206	552	222	532	232	521	240
	9	675	177	639	192	605	208	570	224	550	234	-	-
	10	695	180	658	195	623	211	588	227	567	237	-	-
11	721	182	681	197	644	213	607	230	585	239	-	-	
670	6	695	185	657	202	621	220	585	238	563	249	551	258
	7	718	188	679	205	<b>642</b>	<b>223</b>	605	241	583	252	570	261
	8	741	191	701	208	663	226	625	244	603	255	590	263
	9	764	194	723	211	685	229	646	247	622	257	-	-
	10	787	197	746	214	706	232	666	249	642	260	-	-
11	816	200	771	217	729	234	687	252	662	263	-	-	
740	6	773	208	731	227	692	248	652	269	628	282	615	292
	7	798	211	755	230	<b>715</b>	<b>251</b>	675	272	650	285	636	295
	8	823	214	780	233	738	254	697	275	672	287	658	297
	9	849	217	804	236	762	257	720	278	694	290	-	-
	10	874	220	828	239	785	260	742	280	716	293	-	-
11	905	223	857	242	811	263	766	284	738	296	-	-	
800	6	831	228	786	250	744	273	701	296	676	310	661	321
	7	858	232	812	253	<b>769</b>	<b>276</b>	726	299	699	313	685	324
	8	886	235	839	256	794	279	750	302	723	316	708	327
	9	913	239	865	260	819	282	774	305	747	319	-	-
	10	940	242	891	263	845	286	798	308	770	322	-	-
11	973	245	921	266	872	289	823	312	794	326	-	-	
900	6	933	262	878	283	827	305	776	328	745	342	728	353
	7	964	266	908	287	<b>856</b>	<b>310</b>	804	333	772	346	755	357
	8	995	271	938	292	885	315	832	337	800	350	782	361
	9	1.026	276	969	297	914	319	860	341	827	355	-	-
	10	1.058	281	999	302	943	324	888	346	855	359	-	-
11	1.096	286	1.034	306	975	329	917	351	882	364	-	-	
1000	6	1.021	290	965	314	912	340	859	367	828	382	810	395
	7	1.055	295	997	319	<b>943</b>	<b>345</b>	889	371	856	387	837	399
	8	1.088	300	1.029	324	974	350	918	376	885	391	865	404
	9	1.121	305	1.061	329	1.004	354	947	380	913	396	-	-
	10	1.155	310	1.093	334	1.035	359	976	385	941	400	-	-
11	1.196	315	1.130	339	1.068	364	1.007	390	970	405	-	-	
1150	6	1.170	312	1.106	338	1.045	367	984	395	948	412	927	426
	7	1.208	318	1.142	344	<b>1.080</b>	<b>372</b>	1.018	400	980	417	959	431
	8	1.246	323	1.179	349	1.115	377	1.051	405	1.013	422	991	435
	9	1.284	329	1.215	354	1.150	382	1.085	410	1.046	427	-	-
	10	1.323	334	1.252	360	1.185	387	1.118	415	1.078	431	-	-
11	1.369	339	1.294	365	1.224	393	1.153	420	1.111	437	-	-	

TW= Outlet water temperature °C

kWf = Cooling capacity (kW).

kWa = Compressor power input (kW)

The standard performances refer to a 5°C temperature difference between the water entering and leaving the heat exchanger and to operation of the unit with all fans at top speed. A  $0.44 \times 10^{-4} \text{ m}^2 \text{ K/W}$  fouling factor has also been considered with the unit installed at zero meters above sea level (Pb = 1013mbar).

: in these working points the unit works with fans at the maximum speed.

## GENERAL SPECIFICATIONS - IR UNIT FOR COOLING MODE ONLY

**Acoustic Version: ASS (Extra Low Noise Version)**

The following data refer to an **IR** unit using **R134a** refrigerant

Model	330.2	370.2	420.2	470.2	510.2	590.2	670.2	740.2	800.2	900.2	1000.2	1150.2	UM
Cooling capacity <sup>(1)</sup>	307	351	391	435	490	551	636	699	754	865	943	1076	kW
Total power input <sup>(1)</sup>	123	138	155	173	190	226	245	273	298	329	368	403	kW
EER <sup>(1)</sup>	2,49	2,55	2,52	2,51	2,58	2,44	2,60	2,56	2,53	2,63	2,56	2,67	W/W
ESEER	3,50	3,58	3,50	3,48	3,56	3,37	3,61	3,56	3,52	3,69	3,59	3,78	W/W
Refrigerant charge	Take as reference the refrigerant charge value on the Unit Identification plate												kg

### Compressor specifications

Type	TWIN-SCREW												-
Quantity	2												N°
Capacity control	25-100 %												%
Starting type	PART WINDING						STAR-DELTA						-
Power input	117	131	149	167	182	218	235	262	287	317	355	387	kW

### Exchanger data

Type	SHELL AND TUBE HEAT EXCHANGER												-
Quantity	1												N°
Maximum pressure on wet side													kPa
Total water capacity	113	108	159	159	154	263	256	241	241	419	410	401	l
Water flow rate <sup>(1)</sup>	14,6	16,8	18,7	20,8	23,4	26,3	30,4	33,4	36,0	41,3	45,1	51,4	l/s
Water pressure drop <sup>(1)</sup>	42	53	39	48	49	46	40	40	46	56	39	52	ka

### Fan specifications

Quantity	8	8	8	8	10	10	12	14	14	16	16	20	N°	
Diameter [ Ø ]	800													
Nominal/Maximum rotation speed	550/670												rpm	
Maximum motor input power	2												kW	
Total air flow rate	nom	28080	26820	26100	25200	33376	31360	40081	45200	43960	534900	50260	62860	l/s
	max	41310	41310	40500	39690	51408	49392	46368	57600	55683	69237	64998	74313	l/s
Total power input	nom	5,6	5,6	5,6	5,6	7,0	7,0	8,4	9,8	9,8	11,2	11,2	14,0	kW
	max	8,8	8,8	8,8	8,8	11,0	11,0	13,2	15,4	15,4	17,6	17,6	22,0	kW

### Electrical specifications

Electric power supply	400 / 3 / 50												V/ph-Hz
FLA Maximum current input	258	288	316	344	389	449	454	537	574	661	723	732	A
FLI Maximum power input	157	177	193	209	233	273	275	330	355	402	442	446	kW
MIC Maximum surge current	488	576	673	701	818	901	906	731	768	935	1030	1039	A

#### NOTES:

(1): The data refer to: Water temperature: inlet: 12°C - outlet: 7°C, Outdoor air temperature 35°C D.B.

### Specifications of coils with extended surfaces

Type	Copper pipes notched aluminium fins												/				
Quantity	4												4/8	N°			
Total area	18			22.4			26.9			31.4			35.9			44.9	m²

### Noise levels

Total SWL	87	87	87	87	88	88	90	91	91	92	92	93	dB(A)
SPL 1 m	67	67	67	67	68	68	69	69	69	70	70	71	dB(A)
SPL 5 m	59	59	59	59	61	61	62	63	63	63	63	65	dB(A)
SPL 10 m	55	55	55	55	56	56	57	58	58	59	59	60	dB(A)

The noise levels refer to units operating in the nominal conditions (water temperature: inlet: 12°C - outlet: 7°C, Outdoor air temperature 35°C). The acoustic pressure levels are measured 1/ 5 / 10 meters away from the outer surface of the unit operating in the free field and resting on a reflecting surface (directional factor of 2).

**SWL** = Sound power levels, with reference to  $2 \times 10^{-12}$  W.

The **Total** sound power level in **dB(A)** measured in compliance with **ISO 9614** standards, is certified according to the **Eurovent** certification program. Eurovent certification (**E**) exclusively refers to the **Total** Sound Power in **db(A)**, which is therefore the only binding acoustic specification (the values of the Octave bands in the table are indicative).

**SPL** = Sound pressure levels, with reference to  $2 \times 10^{-5}$  Pa.

The sound pressure levels are values calculated by applying the **ISO-3744 relation (Eurovent 8/1)** and refer to a distance of 1 meter away from the external surface of units operating in the open field with directivity factor 2 and the units operating in nominal conditions in the cooling mode.

# GENERAL SPECIFICATIONS - IR UNIT FOR COOLING MODE ONLY

## Standard performances - Extra low noise Version ASS

MODEL	TW	OUTDOOR AIR TEMPERATURE (°C D.B.)											
		25		30		35		40		43		45	
		kWf	kWa	kWf	kWa	kWf	kWa	kWf	kWa	kWf	kWa	kWf	kWa
330	6	336	98	315	107	296	116	277	125	266	130	259	134
	7	347	100	326	108	<b>307</b>	<b>117</b>	288	126	276	131	269	135
	8	359	102	338	110	318	118	298	127	286	132	279	137
	9	370	103	349	111	328	120	308	128	296	134	-	-
	10	382	105	360	113	339	121	318	130	306	135	-	-
370	6	381	110	359	119	339	129	319	139	307	145	300	150
	7	394	112	372	121	<b>351</b>	<b>131</b>	330	141	318	147	311	152
	8	407	114	384	123	363	133	342	142	329	148	322	153
	9	419	116	396	125	375	134	353	144	340	150	-	-
	10	432	118	409	126	386	136	364	145	351	151	-	-
420	6	424	124	400	135	378	147	356	159	343	167	335	172
	7	438	126	414	137	<b>391</b>	<b>149</b>	368	161	355	168	347	174
	8	452	128	427	139	404	151	381	163	367	170	359	175
	9	466	130	441	141	417	153	393	164	379	171	-	-
	10	480	132	454	143	430	154	406	166	391	173	-	-
470	6	470	138	445	151	421	165	397	179	382	188	374	195
	7	486	140	460	153	<b>435</b>	<b>167</b>	410	181	396	190	387	196
	8	501	142	474	155	449	169	424	183	409	191	400	198
	9	516	144	489	157	463	171	438	185	422	193	-	-
	10	532	146	504	159	478	173	451	187	436	195	-	-
510	6	533	154	502	166	473	179	444	193	427	201	417	118
	7	551	156	520	169	<b>490</b>	<b>182</b>	460	195	442	203	432	120
	8	569	159	537	172	507	185	476	198	458	206	448	121
	9	587	162	555	174	524	187	493	200	474	208	-	-
	10	605	165	572	177	540	190	509	203	490	211	-	-
590	6	596	181	564	197	533	215	502	233	483	244	473	252
	7	616	184	583	200	<b>551</b>	<b>218</b>	519	236	500	246	489	255
	8	636	187	602	203	569	221	537	238	517	249	506	257
	9	656	190	621	206	587	224	554	241	534	251	-	-
	10	676	193	640	209	606	226	572	244	551	254	-	-
670	6	688	195	651	213	615	232	579	251	558	263	546	272
	7	711	198	673	216	<b>636</b>	<b>235</b>	599	254	577	266	565	275
	8	734	202	695	219	657	238	620	257	597	268	584	277
	9	757	205	717	222	678	241	640	260	617	271	-	-
	10	780	208	739	225	699	244	660	263	636	274	-	-
740	6	756	217	715	237	676	259	637	281	614	294	601	305
	7	780	220	739	240	<b>699</b>	<b>262</b>	659	284	636	297	622	308
	8	805	223	762	243	722	265	682	287	657	300	643	310
	9	830	226	786	246	745	268	704	290	679	303	-	-
	10	854	230	810	250	768	271	726	293	700	306	-	-
800	6	815	238	771	260	729	284	688	308	663	322	648	334
	7	842	241	797	263	<b>754</b>	<b>287</b>	711	311	686	325	671	337
	8	868	245	822	266	779	290	735	314	709	329	694	340
	9	895	248	848	270	803	294	759	317	732	332	-	-
	10	922	251	874	273	828	297	783	321	755	335	-	-
900	6	942	267	887	289	836	312	784	336	753	350	735	361
	7	974	272	918	294	<b>865</b>	<b>317</b>	812	340	780	354	763	365
	8	1.006	278	948	299	894	322	841	345	808	358	790	369
	9	1.037	283	979	304	924	326	869	349	836	363	-	-
	10	1.069	288	1.009	309	953	331	897	354	864	367	-	-
1000	6	1.021	298	965	323	912	350	859	377	828	394	810	407
	7	1.055	303	997	328	<b>943</b>	<b>355</b>	889	382	856	398	837	411
	8	1.088	308	1.029	333	974	360	918	387	885	403	865	415
	9	1.121	314	1.061	338	1.004	365	947	391	913	407	-	-
	10	1.155	319	1.093	343	1.035	370	976	396	941	412	-	-
1150	6	1.165	325	1.102	352	1.041	382	981	411	944	429	924	443
	7	1.204	331	1.138	358	<b>1.076</b>	<b>387</b>	1.014	416	977	434	956	448
	8	1.242	336	1.174	363	1.111	392	1.047	421	1.009	439	988	453
	9	1.280	342	1.211	369	1.146	398	1.081	426	1.042	444	-	-
	10	1.318	348	1.247	374	1.181	403	1.114	432	1.074	449	-	-
	11	1.364	353	1.290	380	1.219	408	1.149	437	1.107	454	-	-

TW= Outlet water temperature °C

kWf = Cooling capacity (kW).

kWa = Compressor power input (kW)

The standard performances refer to a 5°C temperature difference between the water entering and leaving the heat exchanger and to operation of the unit with all fans at top speed. A  $0.44 \times 10^{-4} \text{ m}^2 \text{ K/W}$  fouling factor has also been considered with the unit installed at zero meters above sea level (Pb = 1013mbar).

: in these working points the unit works with fans at the maximum speed.

## GENERAL SPECIFICATIONS - IR UNIT FOR COOLING MODE ONLY

### Brine Version (VI)

Correction factors to apply to the basic version data

Brine percentage	20%						
freezing point [°C]	-8						
Produced water temperature	4	2	0	-2	-4	-6	-8
Refrigerating power c.f.	0,912	0,855	0,798	0,738	0,683	-	-
Power input c.f.	0,967	0,957	0,947	0,927	0,897	-	-
Water flow rate c.f.	0,984	0,899	0,821	0,750	0,685	0,620	0,561
Loss of head c.f.	1,289	1,071	0,890	0,740	0,615	0,490	0,390

Brine percentage	30%						
freezing point [°C]	-14						
Produced water temperature	4	2	0	-2	-4	-6	-8
Refrigerating power c.f.	0,899	0,842	0,785	0,725	0,670	0,613	0,562
Power input c.f.	0,960	0,950	0,940	0,920	0,890	0,870	0,840
Water flow rate c.f.	1,013	0,928	0,851	0,780	0,715	0,650	0,591
Loss of head c.f.	1,431	1,184	0,979	0,810	0,670	0,530	0,419

Brine percentage	40%						
freezing point [°C]	-22						
Produced water temperature	4	2	0	-2	-4	-6	-8
Refrigerating power c.f.	0,884	0,827	0,770	0,710	0,655	0,598	0,547
Power input c.f.	0,880	0,870	0,860	0,840	0,810	0,790	0,760
Water flow rate c.f.	1,062	0,970	0,887	0,810	0,740	0,670	0,607
Loss of head c.f.	1,542	1,279	1,061	0,880	0,730	0,580	0,461

A calculation example showing how the table is used is given below.

Consider unit **IR 590.2** in the Basic Version with:

- Refrigerating power of the Basic Version unit (VB):  $P_{f_{VB}} = 594 \text{ kW}$
- Power draw of the Compressors in the Basic Version unit (VB):  $Pass_{CP,VB} = 191 \text{ kW}$
- Water Flow Rate of the Basic Version unit (VB):  $Q_{VB} = 28.4 \text{ l/s}$
- Load losses of the Basic Version unit (VB):  $\Delta p_{VB} = 53 \text{ kPa}$
- with 30% brine and -2°C temperature of the water produced

The corresponding values for the Brine Version are:

- Refrigerating power  $P_{f_{VI}} = P_{f_{VB}} \times (0.725) = 431 \text{ kW}$
- Compressor power draw  $Pass_{CP,VI} = Pass_{CP,VB} \times (0.92) = 176 \text{ kW}$
- Water flow rate  $Q_{VI} = Q_{VB} \times (0.81) = 23 \text{ l/s}$
- Losses of head  $\Delta p_{VI} = \Delta p_{VB} \times (0.88) = 47 \text{ kPa}$

If you need to calculate the performances of the unit with outdoor air temp. different than 35°C, you have to use the values for  $P_{f_{VB}}$  and  $Pass_{CP,VB}$  reported on the tables standard performances for the requisited air temp. and with water leaving temp=7°C.

With  $P_{f_{VB}}$  calculate  $Q_{VB}$  and using the graph water pressure loss Basic Version you have  $\Delta p_{VB}$ . Then apply the corrective coefficients indicated on the tables for VI.

**TECHNICAL SPECIFICATIONS FOR RECOVERY VERSION  
IR UNITS FOR COOLING ONLY**

**Version with Desuperheater (VD)**

**Recovery heat exchanger specifications**

Model	330.2	370.2	420.2	470.2	510.2	590.2	670.2	740.2	800.2	900.2	1000.2	1150.2	UM
Type of recovery exchanger	A											B	
Quantity	2												N°
Max. operating pressure on wet side	1000												kPa
Total water content of recovery exchangers	8	8	9	10	10	13	13	16	20	20	28	46	l

**A:** STAINLESS STEEL BRAZE PLATES

**B:** SHELL AND TUBE

The data refer to: Water temperature: evaporator inlet :12°C - evaporator outlet: 7°C, Outdoor air temperature 35°C.

The data refer to: Water temperature: recovery inlet :40°C - recovery outlet: 45°C.

**Technical specifications of Basic Version**

Model	330.2	370.2	420.2	470.2	510.2	590.2	670.2	740.2	800.2	900.2	1000.2	1150.2	UM
Recovered heating capacity	93	109	122	135	152	171	185	212	231	266	292	313	kW
Recovered water flow rate	4,5	5,2	5,8	6,4	7,2	8,2	8,8	10,1	11,1	12,7	14,0	15,0	l/s
Recovered water pressure drop	10	13	17	10	13	12	14	18	15	12	15	17	kPa

**Technical specifications of Low noise version**

Model	330.2	370.2	420.2	470.2	510.2	590.2	670.2	740.2	800.2	900.2	1000.2	1150.2	UM
Recovered heating capacity	97	113	127	141	157	182	200	225	247	278	309	334	kW
Recovered water flow rate	4,6	5,4	6,1	6,7	7,5	8,7	9,6	10,8	11,8	13,3	14,8	15,9	l/s
Recovered water pressure drop	11	15	19	11	14	14	16	21	17	13	17	20	kPa

**Technical specifications of Extra low noise Version**

Model	330.2	370.2	420.2	470.2	510.2	590.2	670.2	740.2	800.2	900.2	1000.2	1150.2	UM
Recovered heating capacity	105	118	134	150	164	195	211	235	257	284	318	347	kW
Recovered water flow rate	5,0	5,6	6,4	7,2	7,8	9,3	10,1	11,2	12,3	13,6	15,2	16,6	l/s
Recovered water pressure drop	13	16	20	12	15	16	18	23	19	14	18	21	kPa

**TECHNICAL SPECIFICATIONS FOR RECOVERY VERSION  
IR UNITS FOR COOLING ONLY**

**Recovered heating capacity in Version with Desuperheater (VD)**

MODEL	TWR	OUTDOOR AIR TEMPERATURE (°C D.B.)																	
		Basic version						Low noise version						Extra low noise version					
		20	25	30	35	40	45	20	25	30	35	40	45	20	25	30	35	40	45
		kW <sub>t</sub> = RECOVERED HEATING CAPACITY [KW]																	
330	40	64,6	70,4	91,9	102,3	114,6	126,9	67,4	73,4	95,9	106,7	119,5	132,3	73,0	79,5	103,8	115,5	129,4	143,2
	45	47,7	64,0	83,6	<b>93</b>	104,2	115,3	49,7	66,8	87,2	<b>97</b>	108,6	120,3	53,8	72,3	94,4	<b>105</b>	117,6	130,2
	50	30,7	47,2	67,0	83,7	94,9	106,3	32,0	49,3	69,8	87,3	98,9	110,8	34,7	53,3	75,6	94,5	107,1	120,0
370	40	75,8	82,5	107,8	119,9	134,3	148,7	78,5	85,6	111,7	124,3	139,2	154,1	82,0	89,3	116,6	129,8	145,4	161,0
	45	55,9	75,0	98,0	<b>109</b>	122,1	135,2	57,9	77,8	101,6	<b>113</b>	126,6	140,1	60,5	81,2	106,0	<b>118</b>	132,2	146,3
	50	36,0	55,4	78,5	98,1	111,2	124,5	37,3	57,4	81,4	101,7	115,3	129,1	38,9	59,9	85,0	106,2	120,4	134,8
420	40	84,8	92,4	120,6	134,2	150,3	166,4	88,3	96,2	125,5	139,7	156,5	173,2	93,1	101,5	132,5	147,4	165,1	182,8
	45	62,5	84,0	109,6	<b>122</b>	136,6	151,3	65,1	87,4	114,1	<b>127</b>	142,2	157,5	68,7	92,2	120,4	<b>134</b>	150,1	166,2
	50	40,3	62,0	87,8	109,8	124,4	139,4	41,9	64,5	91,4	114,3	129,5	145,1	44,2	68,0	96,5	120,6	136,7	153,1
470	40	93,8	102,2	133,5	148,5	166,3	184,1	98,0	106,8	139,4	155,1	173,7	192,3	104,3	113,6	148,3	165,0	184,8	204,6
	45	69,2	92,9	121,3	<b>135</b>	151,2	167,4	72,3	97,1	126,7	<b>141</b>	157,9	174,8	76,9	103,2	134,8	<b>150</b>	168,0	186,0
	50	44,6	68,6	97,2	121,5	137,7	154,2	46,5	71,6	101,5	126,9	143,8	161,1	49,5	76,2	108,0	135,0	153,0	171,4
510	40	105,6	115,1	150,3	167,2	187,3	207,3	109,1	118,9	155,2	172,7	193,4	214,1	114,0	124,2	162,1	180,4	202,0	223,7
	45	77,9	104,6	136,6	<b>152</b>	170,2	188,5	80,5	108,1	141,1	<b>157</b>	175,8	194,7	84,1	112,9	147,4	<b>164</b>	183,7	203,4
	50	50,2	77,2	109,4	136,8	155,0	173,7	51,8	79,7	113,0	141,3	160,1	179,4	54,1	83,3	118,1	147,6	167,3	187,4
590	40	118,9	129,5	169,0	188,1	210,7	233,2	126,5	137,8	179,9	200,2	224,2	248,2	135,5	147,6	192,8	214,5	240,2	266,0
	45	87,6	117,7	153,7	<b>171</b>	191,5	212,0	93,3	125,3	163,6	<b>182</b>	203,8	225,7	100,0	134,2	175,2	<b>195</b>	218,4	241,8
	50	56,4	86,8	123,1	153,9	174,4	195,4	60,1	92,4	131,0	163,8	185,6	208,0	64,4	99,0	140,4	175,5	198,9	222,8
670	40	128,6	140,1	182,9	203,5	227,9	252,3	139,0	151,4	197,7	220,0	246,4	272,8	146,7	159,8	208,6	232,1	260,0	287,8
	45	94,8	127,3	166,3	<b>185</b>	207,2	229,4	102,5	137,7	179,7	<b>200</b>	224,0	248,0	108,2	145,2	189,6	<b>211</b>	236,3	261,6
	50	61,1	93,9	133,2	166,5	188,7	211,4	66,0	101,6	144,0	180,0	204,0	228,5	69,6	107,1	151,9	189,9	215,2	241,1
740	40	147,4	160,5	209,6	233,2	261,2	289,2	156,4	170,4	222,4	247,5	277,2	306,9	163,3	177,9	232,3	258,5	289,5	320,5
	45	108,7	145,9	190,5	<b>212</b>	237,4	262,9	115,3	154,9	202,2	<b>225</b>	252,0	279,0	120,5	161,8	211,2	<b>235</b>	263,2	291,4
	50	70,0	107,7	152,6	190,8	216,2	242,2	74,3	114,3	162,0	202,5	229,5	257,1	77,6	119,3	169,2	211,5	239,7	268,5
800	40	160,6	174,9	228,4	254,1	284,6	315,1	171,7	187,0	244,2	271,7	304,3	336,9	178,6	194,6	254,1	282,7	316,6	350,5
	45	118,4	159,0	207,6	<b>231</b>	258,7	286,4	126,6	170,0	222,0	<b>247</b>	276,6	306,3	131,7	176,9	231,0	<b>257</b>	287,8	318,7
	50	76,2	117,3	166,3	207,9	235,6	263,9	81,5	125,4	177,8	222,3	251,9	282,2	84,8	130,5	185,0	231,3	262,1	293,6
900	40	184,9	201,4	263,0	292,6	327,7	362,8	193,2	210,5	274,8	305,8	342,5	379,2	197,4	215,0	280,7	312,4	349,9	387,4
	45	136,3	183,1	239,0	<b>266</b>	297,9	329,8	142,5	191,4	249,8	<b>278</b>	311,4	344,7	145,6	195,5	255,2	<b>284</b>	318,1	352,2
	50	87,8	135,1	191,5	239,4	271,3	303,9	91,8	141,2	200,2	250,2	283,6	317,6	93,7	144,2	204,5	255,6	289,7	324,5
1000	40	203,0	221,1	288,7	321,2	359,7	398,3	214,8	234,0	305,5	339,9	380,7	421,5	221,0	240,8	314,4	349,8	391,8	433,8
	45	149,7	201,0	262,4	<b>292</b>	327,0	362,1	158,4	212,7	277,7	<b>309</b>	346,1	383,2	163,0	218,9	285,8	<b>318</b>	356,2	394,3
	50	96,4	148,3	210,2	262,8	297,8	333,6	102,0	156,9	222,5	278,1	315,2	353,1	105,0	161,5	229,0	286,2	324,4	363,3
1150	40	217,6	237,0	309,4	344,3	385,6	426,9	232,2	252,9	330,2	367,4	411,5	455,6	241,2	262,7	343,0	381,7	427,5	473,3
	45	160,4	215,4	281,3	<b>313</b>	350,6	388,1	171,2	229,9	300,2	<b>334</b>	374,1	414,2	177,9	238,8	311,8	<b>347</b>	388,6	430,3
	50	103,3	158,9	225,4	281,7	319,3	357,6	110,2	169,6	240,5	300,6	340,7	381,6	114,5	176,2	249,8	312,3	353,9	396,5

The standard performances refer to a 5°C temperature difference between the water entering and leaving the heat exchanger and to operation of the unit with all fans at top speed. A  $0.44 \times 10^{-4} \text{ m}^2 \text{ K/W}$  fouling factor has also been considered with the unit installed at zero meters above sea level (Pb = 1013mbar).

TWE: Evaporator outlet water temperature (°C)

TWR: Recovered water temperature (°C)

## TECHNICAL SPECIFICATIONS FOR RECOVERY VERSION IR UNITS FOR COOLING ONLY

### Version with total recovery on all circuits (VR)

#### Recovery heat exchanger specifications

Type of recovery exchanger	A										B		
Quantity	2												N°
Max. operating pressure on wet side	1000												kPa
Total water content of recovery exchangers	40	42	42	55	60	75	75	86	100	105	115	115	l

**A:** STAINLESS STEEL BRAZE PLATES

**B:** SHELL AND TUBE

The data refer to: Water temperature: evaporator inlet :12°C - evaporator outlet: 7°C, Outdoor air temperature 35°C.

The data refer to: Water temperature: recovery inlet :40°C - recovery outlet: 45°C (except mod. 1150.2 39/45°C).

#### Technical specifications of Basic Version

Model	330.2	370.2	420.2	470.2	510.2	590.2	670.2	740.2	800.2	900.2	1000.2	1150.2	UM
Recovered heating capacity	429	479	545	614	680	777	855	968	1049	1180	1303	1457	kW
Recovered water flow rate	20,5	22,9	26,0	29,3	32,5	37,1	40,8	46,3	50,1	56,4	62,2	69,6	l/s
Recovered water pressure drop	27	33	43	45	47	43	47	44	52	47	48	50	kPa

#### Recovered heating capacity in Total Recovery Version (VR)

MODEL	TWE	RECOVERED WATER TEMPERATURE (°C D.B.)			
		35	40	45	50
		kW <sub>t</sub> = RECOVERED HEATING CAPACITY [KW]			
<b>330</b>	6	443	429	416	403
	7	457	442	<b>429</b>	415
	8	471	455	441	428
	9	484	468	454	440
	10	498	481	467	452
	11	515	497	481	465
<b>370</b>	6	491	477	465	453
	7	506	491	<b>479</b>	466
	8	521	506	492	479
	9	536	520	506	492
	10	550	534	520	505
	11	568	550	535	519
<b>420</b>	6	558	543	530	517
	7	575	559	<b>545</b>	531
	8	592	575	561	546
	9	608	591	576	561
	10	625	607	591	576
	11	644	625	608	591
<b>470</b>	6	627	611	597	582
	7	646	628	<b>614</b>	599
	8	664	646	631	615
	9	682	664	648	632
	10	701	681	665	648
	11	722	702	683	665
<b>510</b>	6	702	679	660	640
	7	724	700	<b>680</b>	659
	8	745	721	700	679
	9	767	742	720	698
	10	789	763	741	718
	11	815	787	763	738
<b>590</b>	6	795	773	755	736
	7	820	796	<b>777</b>	757
	8	844	820	799	778
	9	868	843	821	799
	10	892	866	843	820
	11	920	892	867	842
<b>670</b>	6	875	851	830	810
	7	902	877	<b>855</b>	833
	8	928	902	879	856
	9	955	927	903	879
	10	981	953	928	902
	11	1013	982	954	927
<b>740</b>	6	991	964	941	919
	7	1020	992	<b>968</b>	945
	8	1049	1020	995	971
	9	1078	1048	1022	997
	10	1107	1076	1050	1023
	11	1142	1108	1079	1050
<b>800</b>	6	1072	1044	1020	996
	7	1104	1074	<b>1049</b>	1024
	8	1135	1105	1078	1052
	9	1167	1135	1108	1080
	10	1198	1166	1137	1108
	11	1236	1200	1169	1138
<b>900</b>	6	1218	1179	1145	1111
	7	1255	1215	<b>1180</b>	1144
	8	1293	1251	1214	1178
	9	1330	1287	1249	1211
	10	1367	1323	1284	1245
	11	1412	1365	1322	1280
<b>1000</b>	6	1336	1299	1266	1234
	7	1376	1337	<b>1303</b>	1269
	8	1416	1375	1339	1304
	9	1456	1413	1376	1339
	10	1495	1451	1412	1373
	11	1543	1495	1452	1410
<b>1150</b>	6	1499	1454	1416	1377
	7	1544	1497	<b>1457</b>	1416
	8	1589	1540	1498	1456
	9	1633	1584	1539	1495
	10	1678	1627	1580	1534
	11	1732	1676	1625	1576

The standard performances refer to a 5°C temperature difference between the water entering and leaving the heat exchanger and to operation of the unit with all fans at top speed. A  $0.44 \times 10^{-4} \text{ m}^2 \cdot \text{K/W}$  fouling factor has also been considered with the unit installed at zero meters above sea level (Pb = 1013mbar).

**TWE:** Evaporator outlet water temperature (°C)

**TWR:** Recovered water temperature (°C)

## NOISE LEVELS

The noise levels refer to units operating in the nominal conditions (water temperature: inlet: 12°C - outlet: 7°C, Outdoor air temperature 35°C). The acoustic pressure levels are measured 1/ 5 / 10 meters away from the outer surface of the unit operating in the free field and resting on a reflecting surface (directional factor of 2).

**SWL** = Sound power levels, with reference to  $2 \times 10^{-12}$  W.

The **Total** sound power level in **dB(A)** measured in compliance with **ISO 9614** standards, is certified according to the **Eurovent** certification program.

Eurovent certification (**E**) exclusively refers to the **Total** Sound Power in **dB(A)**, which is therefore the only binding acoustic specification (the values of the Octave bands in the table are indicative).

**SPL** = Sound pressure levels, with reference to  $2 \times 10^{-5}$  Pa.

The sound pressure levels are values calculated by applying the **ISO-3744 relation (Eurovent 8/1)** and refer to a distance of 1 meter away from the external surface of units operating in the open field with directivity factor 2 and the units operating in nominal conditions in the cooling mode.

### AB Basic Version

Mod.	SWL (dB)										SPL (dBA)		
	Octave bands (Hz)								Total		1m	5m	10m
	63	125	250	500	1000	2000	4000	8000	dB	dB(A)			
330.2	100	99	94	91	94	92	86	79	104	98	78	71	66
370.2	101	99	95	92	94	93	85	80	105	98	78	71	66
420.2	101	100	94	92	94	93	86	80	105	98	78	71	66
470.2	101	100	95	92	94	93	87	80	105	98	78	71	66
510.2	102	100	96	94	96	94	88	80	106	100	79	72	67
590.2	102	100	96	94	96	94	88	80	106	100	79	72	67
670.2	102	100	97	95	96	94	88	80	106	100	79	72	67
740.2	103	101	97	96	97	95	89	81	107	101	80	73	69
800.2	104	102	97	96	97	95	89	82	107	101	80	73	69
900.2	104	102	97	96	98	96	90	83	108	102	81	74	69
1000.2	104	102	98	96	99	96	90	83	108	102	81	74	69
1150.2	104	103	98	96	99	97	90	83	108	103	82	75	70

### AS Low noise version

Mod.	SWL (dB)										SPL (dBA)		
	Octave bands (Hz)								Total		1m	5m	10m
	63	125	250	500	1000	2000	4000	8000	dB	dB(A)			
330.2	99	97	92	90	89	83	77	72	102	93	73	65	61
370.2	100	97	92	90	89	83	77	72	103	93	73	65	61
420.2	100	98	93	90	90	83	78	73	103	93	73	65	61
470.2	100	97	93	91	89	83	78	73	103	93	73	65	61
510.2	101	98	93	91	90	84	78	73	103	94	74	67	62
590.2	101	99	94	91	91	85	79	73	104	94	74	67	62
670.2	101	99	93	91	91	85	79	73	104	94	74	67	62
740.2	102	99	95	93	92	85	80	75	105	96	75	68	63
800.2	102	100	96	93	93	86	80	75	105	96	75	68	63
900.2	102	100	97	94	94	88	81	76	106	97	75	69	64
1000.2	102	100	97	95	94	88	81	75	106	97	75	69	64
1150.2	102	101	98	95	94	88	81	76	106	98	76	69	65

### ASS Extra low noise version

Mod.	SWL (dB)										SPL (dBA)		
	Octave bands (Hz)								Total		1m	5m	10m
	63	125	250	500	1000	2000	4000	8000	dB	dB(A)			
330.2	95	87	87	85	81	76	72	73	97	87	67	59	55
370.2	96	87	87	86	82	76	73	74	97	87	67	59	55
420.2	96	87	87	86	82	77	73	74	97	87	67	59	55
470.2	96	87	87	86	82	78	74	75	97	87	67	59	55
510.2	97	88	87	86	83	79	75	75	98	88	68	61	56
590.2	98	89	88	87	83	79	75	75	99	88	68	61	56
670.2	98	89	89	87	85	80	76	76	99	90	69	62	57
740.2	98	89	90	88	87	81	76	76	100	91	69	63	58
800.2	99	90	91	89	87	81	75	76	101	91	69	63	58
900.2	99	90	91	89	88	82	77	76	101	92	70	63	59
1000.2	100	91	91	90	88	82	78	77	102	92	70	63	59
1150.2	101	91	92	91	89	83	80	77	103	93	71	65	60

## OPERATING RANGE

### Operating range Basic Version

The table below lists the operating ranges within which correct operation of the units is guaranteed, depending on the Version and Operating Mode available for each type of unit.  
Remember that in Heat Pump units, heat recovery only takes place during operation in the cooling mode.

### Operating range of Basic Version

Thermal gradient of the water		Limit value
<b>Minimum</b>	°C	4
<b>Maximum</b>	°C	8

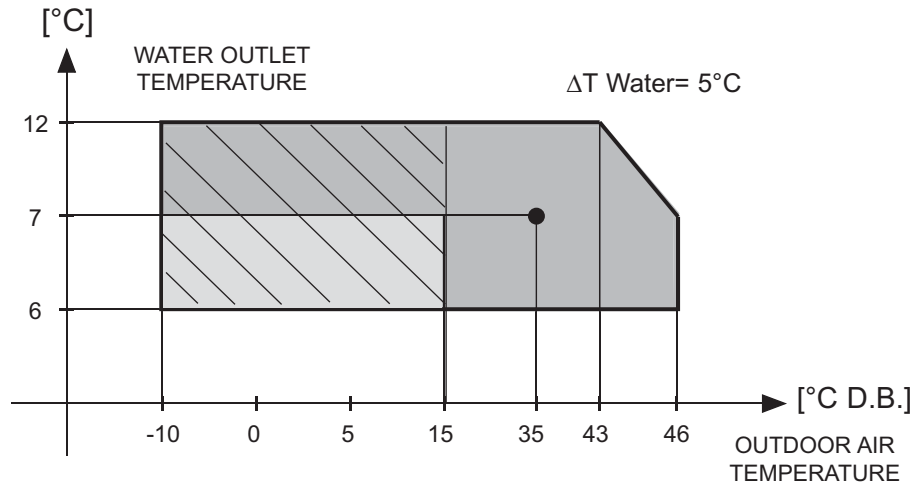

- With accessory Head pressure control (brine is recommended)
- With accessory Head pressure control (standard for AS e ASS)

### Operating range for Recovery version

Version	Limit value
with Desuperheater (VD)	<b>Recovery water temp. from 40 to 50°C</b> (Refer to Desuperheater Standard Performances table)
Total Recovery (VR)	See graphic below

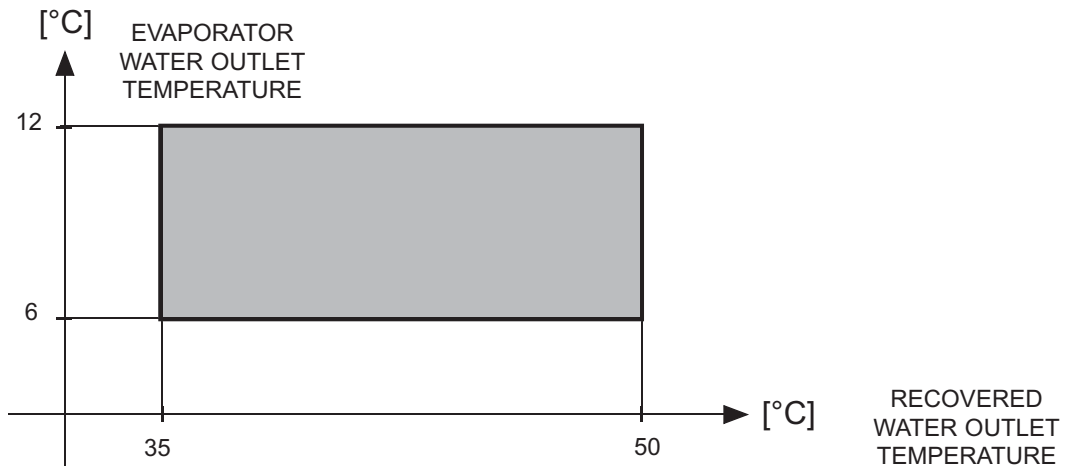

## WATER PRESSURE DROP BASIC VERSION

The graph below illustrates the water pressure drop values in **kPa** depending on the flow rate in **liters/second**. The operating range is delimited by the minimum and maximum values given in the next table.

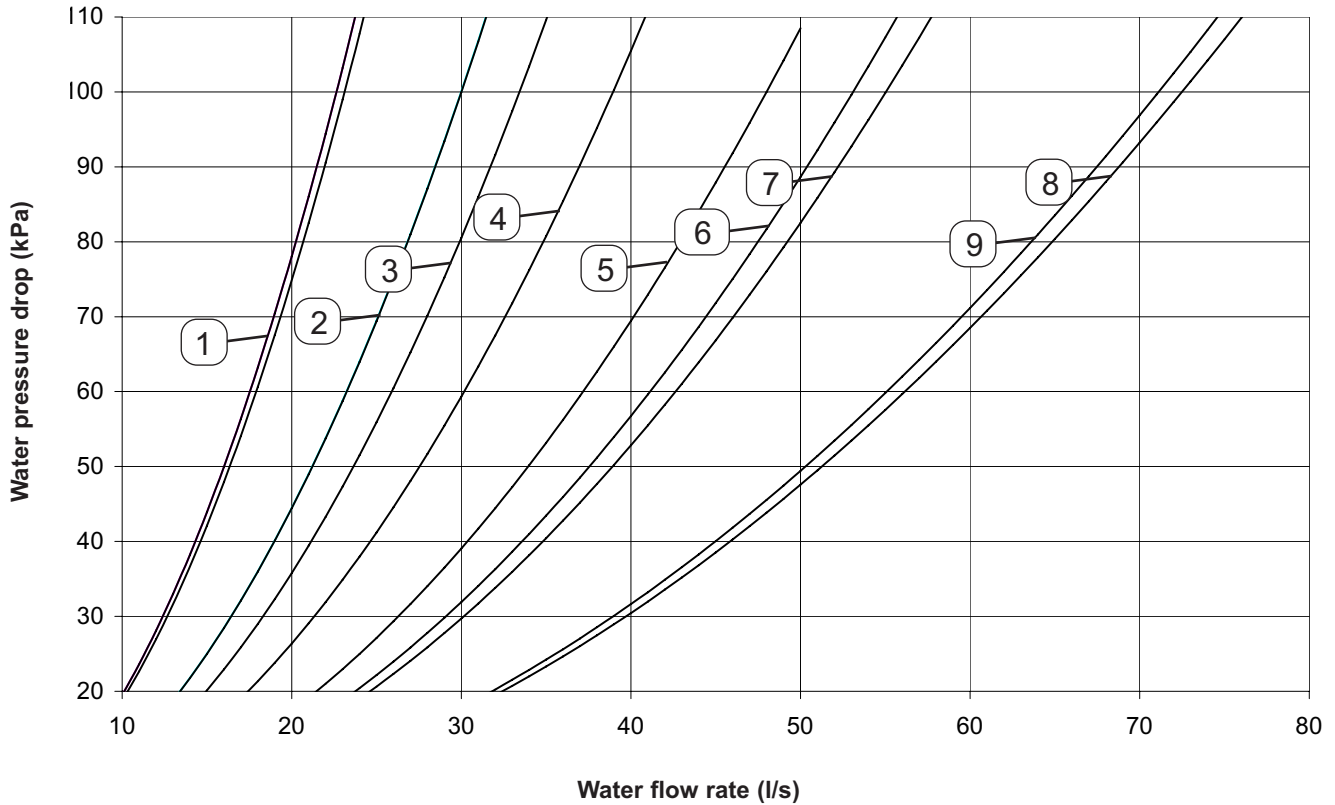

### Operating range

Unit Size		330.2	370.2	420.2	470.2	510.2	590.2	670.2	740.2	800.2	900.2	1000.2	1150.2	UM	NOTES
Graph reference		1	2	3	4	5	6	7	8	9					<b>Q</b> = Water flow rate <b>Δp</b> = Water pressure drop
Lower limit value	<b>Q</b>	10	14	16	17	21	23	24	32	32	l/s				
	<b>Δp</b>	20										kPa			
Upper limit value	<b>Q</b>	23	24	32	35	42	50	57	59	77	77	l/s			
	<b>Δp</b>	120										kPa			

## WATER PRESSURE DROP DESUPERHEATER VERSION

The graph below illustrates the water pressure drop values in **kPa** depending on the flow rate in **liters/second**. The operating range is delimited by the minimum and maximum values given in the next table.

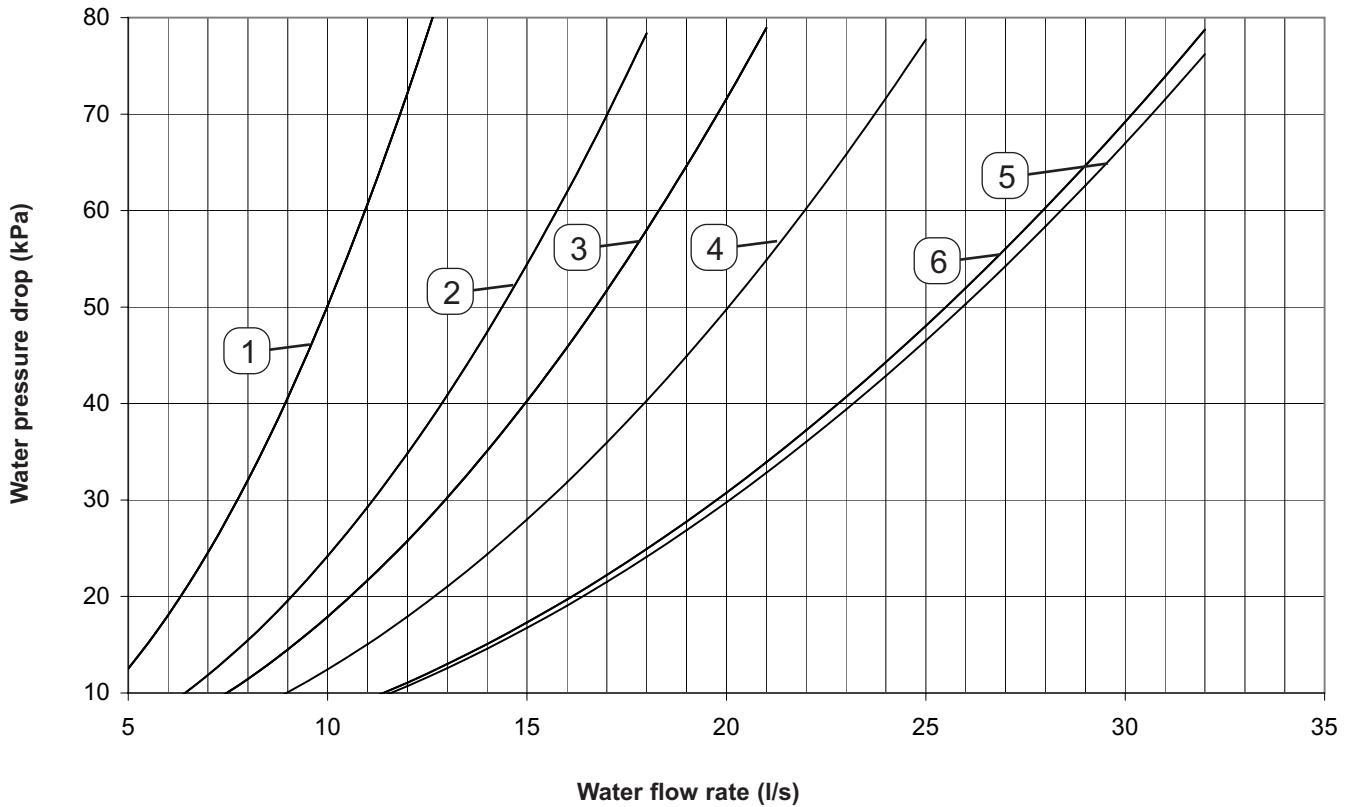

### Operating range

Unit Size		330.2	370.2	420.2	470.2	510.2	590.2	670.2	740.2	800.2	900.2	1000.2	1150.2	UM	NOTES
Graph reference		1			2		3		4	5	6				<b>Q</b> = Water flow rate <b>Δp</b> = Water pressure drop
Lower limit value	<b>Q</b>	2		3		4		5	7				l/s		
	<b>Δp</b>	10											kPa		
Upper limit value	<b>Q</b>	13		18		21		25	32				l/s		
	<b>Δp</b>	80											kPa		

## WATER PRESSURE DROP RECOVERY VERSION

The graph below illustrates the water pressure drop values in **kPa** depending on the flow rate in **liters/second**. The operating range is delimited by the minimum and maximum values given in the next table.

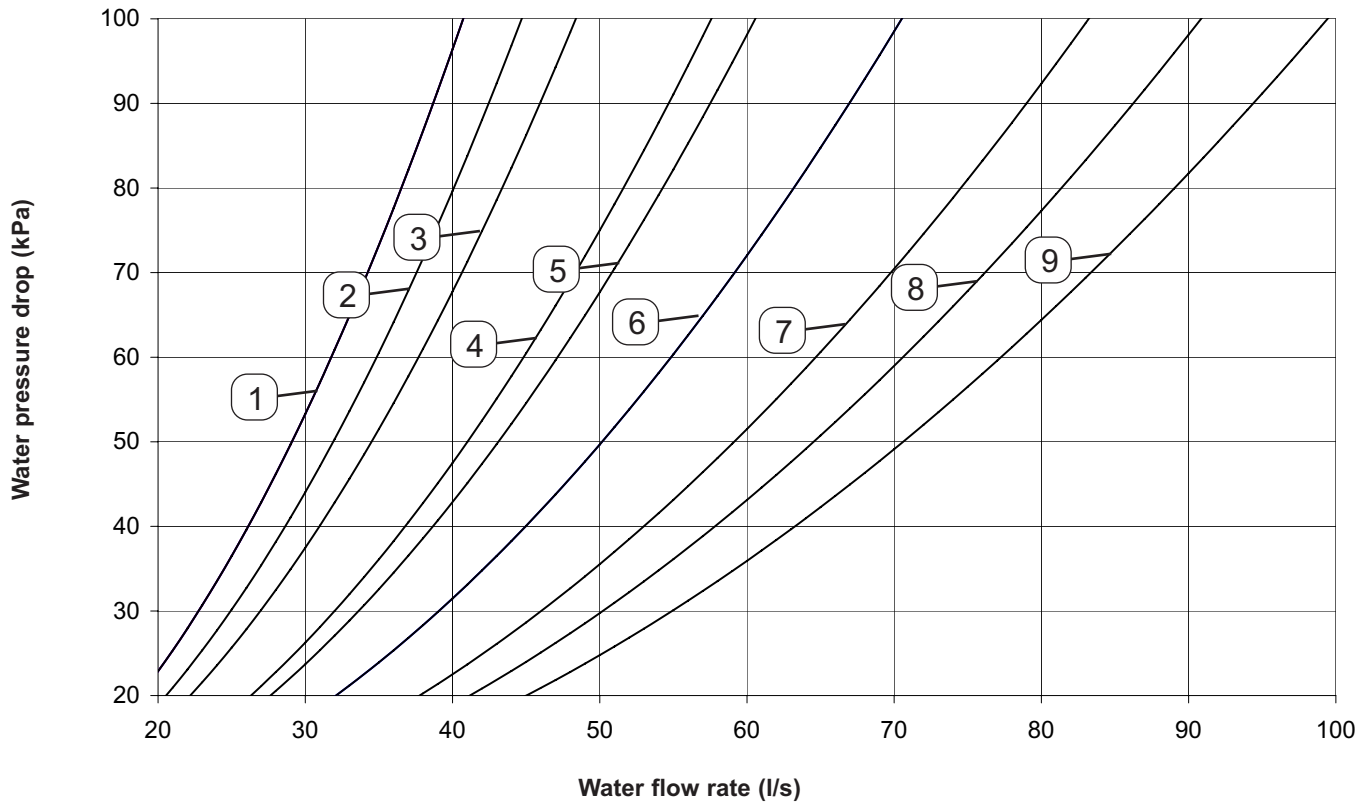

### Operating range

Unit Size	330.2	370.2	420.2	470.2	510.2	590.2	670.2	740.2	800.2	900.2	1000.2	1150.2	UM	NOTES
Graph reference	1		2	3	4	5	6	7	8	9				<b>Q</b> = Water flow rate <b>Δp</b> = Water pressure drop
Lower limit value	<b>Q</b>	19	21	22	26	27	32	38	41	45	l/s			
	<b>Δp</b>	20										kPa		
Upper limit value	<b>Q</b>	41	45	48	58	60	70	83	91	100	l/s			
	<b>Δp</b>	100										kPa		

## DIMENSIONAL DATA

### Dimensional data and weight

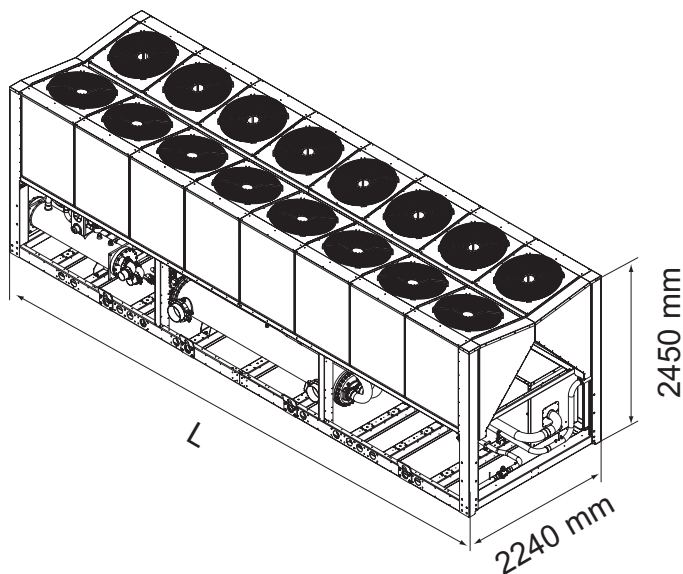

Model	330.2	370.2	42.2	470.2	510.2	590.2	670.2	740.2	800.2	900.2	1000.2	1150.2	UM	
Shipping weight <sup>(1)</sup>	3545	3762	4244	4666	4954	5337	5644	6922	7085	7551	7933	9186	kg	
Operating weight <sup>(1)</sup>	3658	3870	4403	4825	5108	5600	5900	7163	7326	7970	8343	9587	kg	
Length [L]	AB-AS	4070	4070	4070	4070	5005	5005	5005	5950	5950	6900	6900	7810	mm
	ASS	4070	4070	4070	4070	5005	5005	5950	6900	6900	7810	7810	10000	mm

(1) Operating weight of the VB unit of the heaviest series - Extra low noise Version

### Minimum space required for operation

Refer to the figure alongside for the dimensions of the unit.

To correctly install the unit, comply with the measurements for the free area that must be left around the machine, as shown in the figure.

The distances must be doubled if the unit is to be installed in a pit.

**NOTE: Allow for a clear area of not less than 2.5 meters above unit.**

The functional areas must be doubled if multiple units are installed.

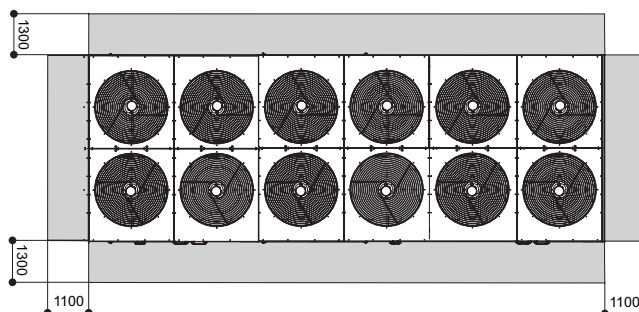

### Victaulic connections

These comprise two wet connections of the Victaulic type (Fig. 1-A) composed by steel joint (Fig. 1-B) and rubber packing not installed (supplied with the unit). The steel joints are suitable to be welded or threaded.

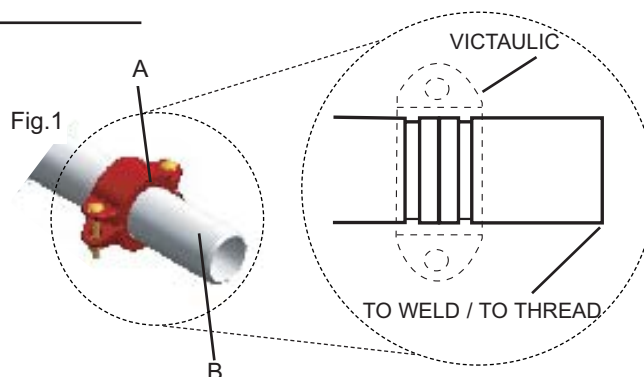

The manufacturer declines all responsibility for any inaccuracies in this manual due to printing or typing errors. The reserves the right to modify the products contents in this catalogue without previous notice.







# ferroli

Cod. 3QE24240



Ferrolì spa - 37047 San Bonifacio (Verona) Italy - Via Ritonda 78/A  
tel. +39.045.6139411 - fax +39.045.6100933 - [www.ferroli.it](http://www.ferroli.it)